

RYOBI®



A	P	R and L	S _{Stop}	S _{Stop}
2VA	2Speed	B.C.	D	L
Torque	8000 Series 500,000 cycles	8000V Series 1,500,000 cycles		

Surface Mounted Door Closer **RYOBI**
8000 SERIES

Surface Mounted Door Closer 8000 SERIES

Model chart

Size	Standard application		Parallel application		Maximum door weight	Maximum door width	
	Without hold-open	With hold-open	Without hold-open	With hold-open		Interior	Exterior
Size1	8001	S-8001	8001P	S-8001P	30kg	800mm	————
Size2	8002	S-8002	8002P	S-8002P	45kg	900mm	800mm
Size3	8003	S-8003	8003P	S-8003P	65kg	950mm	900mm
Size4	8004	S-8004	8004P	S-8004P	85kg	1050mm	950mm
Size5	8005	S-8005	8005P	S-8005P	120kg	1200mm	1050mm
Size6	8006	S-8006	8006P	S-8006P	150kg	1500mm	1350mm

With built-in hold-open type

Size	Standard application	Parallel application	Maximum door weight	Maximum door width	
				Interior	Exterior
Size1	8011	8011P	30kg	800mm	————
Size2	8012	8012P	45kg	900mm	800mm
Size3	8013	8013P	65kg	950mm	900mm

With backcheck type

Size	Standard application		Parallel application		Maximum door weight	Maximum door width	
	Without hold-open	With hold-open	Without hold-open	With hold-open		Interior	Exterior
Size2	8002BC	S-8002BC	8002PBC	S-8002PBC	45kg	900mm	800mm
Size3	8003BC	S-8003BC	8003PBC	S-8003PBC	65kg	950mm	900mm
Size4	8004BC	S-8004BC	8004PBC	S-8004PBC	85kg	1050mm	950mm
Size5	8005BC	S-8005BC	8005PBC	S-8005PBC	120kg	1200mm	1050mm
Size6	8006BC	S-8006BC	8006PBC	S-8006PBC	150kg	1500mm	1350mm

Spring adjustable type

Size	Standard application		Parallel application		Maximum door weight	Maximum door width	
	Without hold-open	With hold-open	Without hold-open	With hold-open		Interior	Exterior
2-6	8000V	S8000V	8000PV	S8000PV	45-150kg	900~1300mm	800~1050mm
1-5	8001V	S8001V	8001PV	S8001PV	30-120kg	800~1200mm	800~950mm

Surface Mounted Door Closer 8000 SERIES

Optional backcheck function
Support of door sizes 1-6
Non-handed
Wide color variation

**Standard application
Without hold-open**

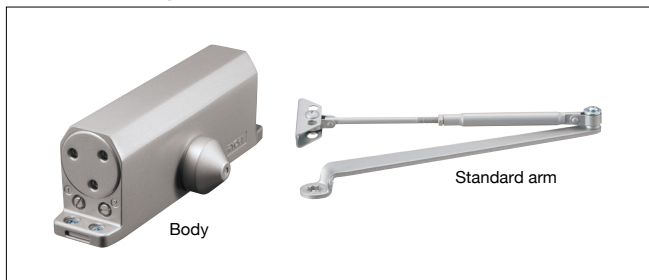

**Standard application
With hold-open**

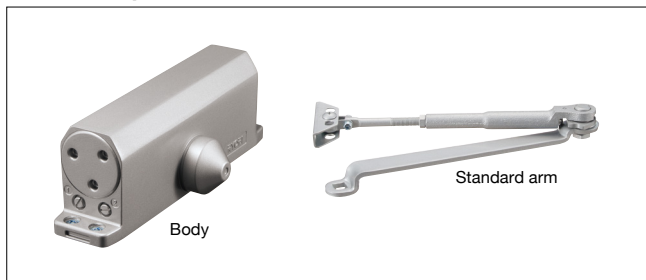

**Parallel application
Without hold-open**

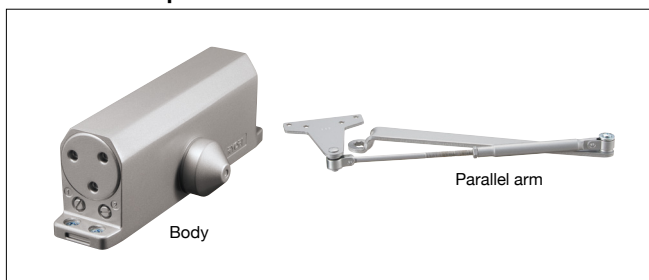

**Parallel application
With hold-open**

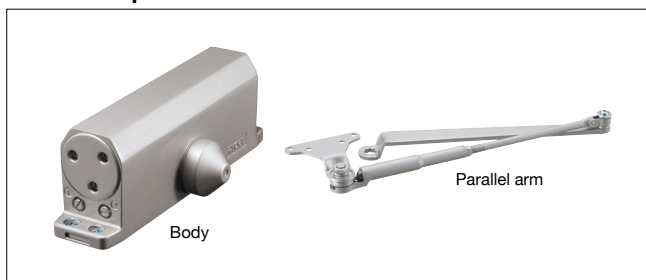

Color variation



※Custom colors may be available

Specification and adjustment

Standard / Parallel application

- The standard type is installed on the pull side, and the parallel type is installed on the push side.

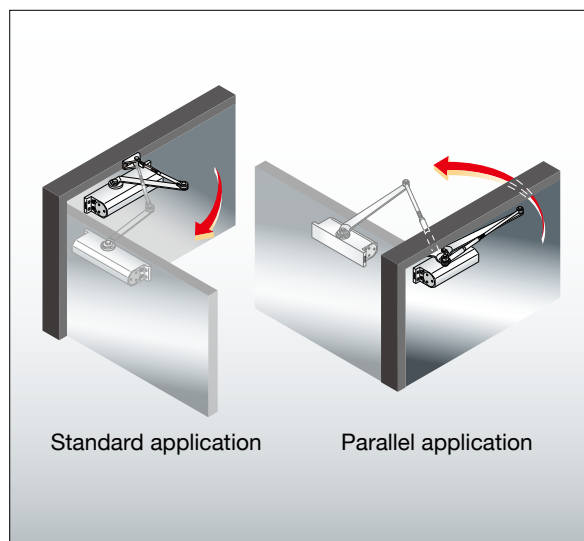

Speed control valves

- There are two speed ranges for door closing speed.
- Those ranges are classified into two stages of the 1st speed range which controls overall door closing speed and the 2nd speed range which controls latching speed.
- Those speeds can be adjusted by independent speed adjustment valve.

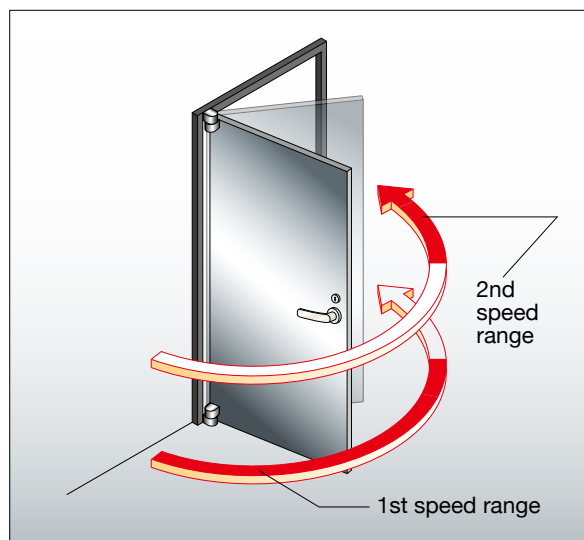
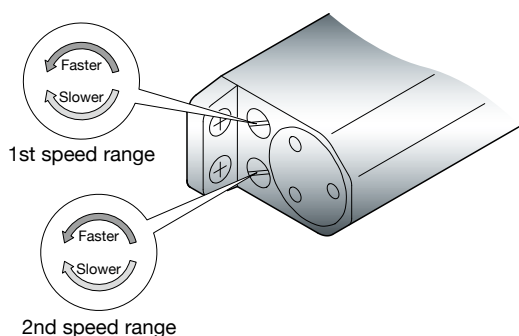

Hold-open device

- The non handed, hold open arm allows a door to be held open at any angles between 70 and 180 degrees.
- The serration type cam never allows a door to fall back. The cam and bearing type hold open mechanism ensures adequate hold open force by adjustable hold open force.

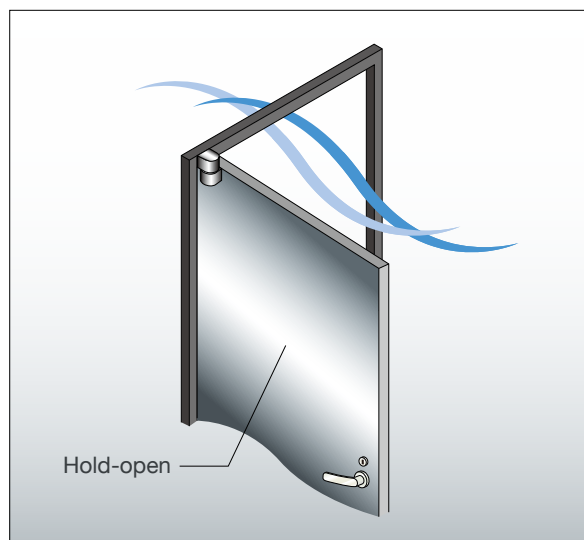

Backcheck function

- This function prevents accidents, injuries, and door damage which occur due to a door suddenly opening by a strong wind or rough handling.
- This function works in a range of door opening angles from approx. 80 to 180 degrees.
- The door becomes heavier when it operates, however, this is all by design. The door opens if it is slowly opened.
- When installing the door closer equipped with the backcheck function, sufficiently reinforce hinges and pivots.

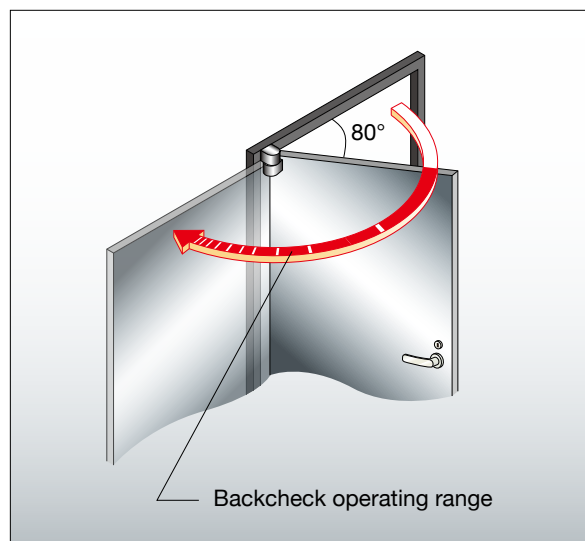
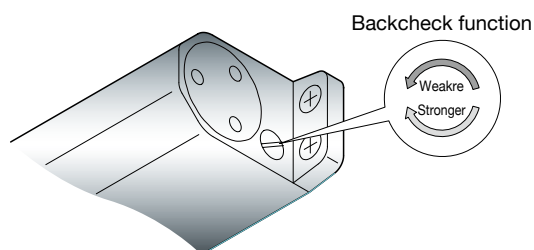

Closing power adjustment (8000V and 8001V)

- Spring power adjustable according to door weight and width,
- Factory preset size 3 standard installation.

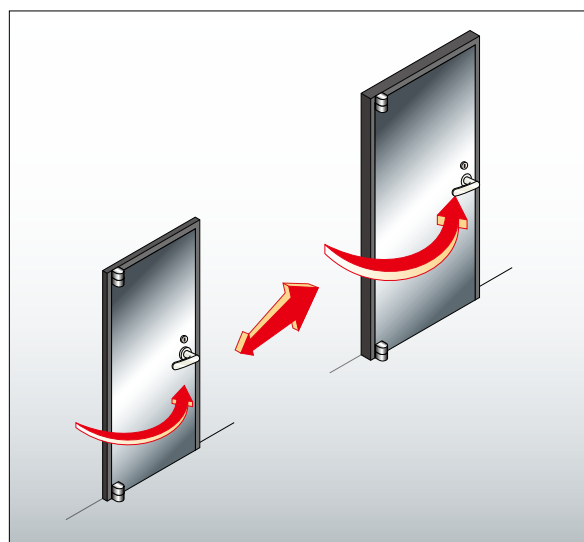
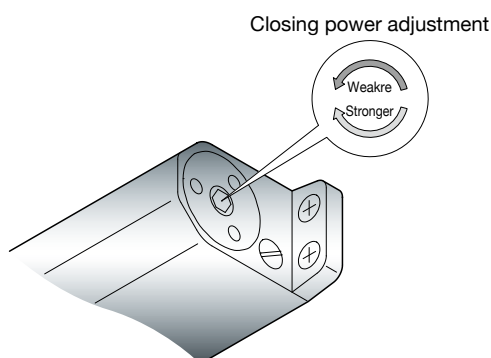

Standard application / Without hold-open



Standard application / With hold-open



Parallel application / Without hold-open



Parallel application / With hold-open

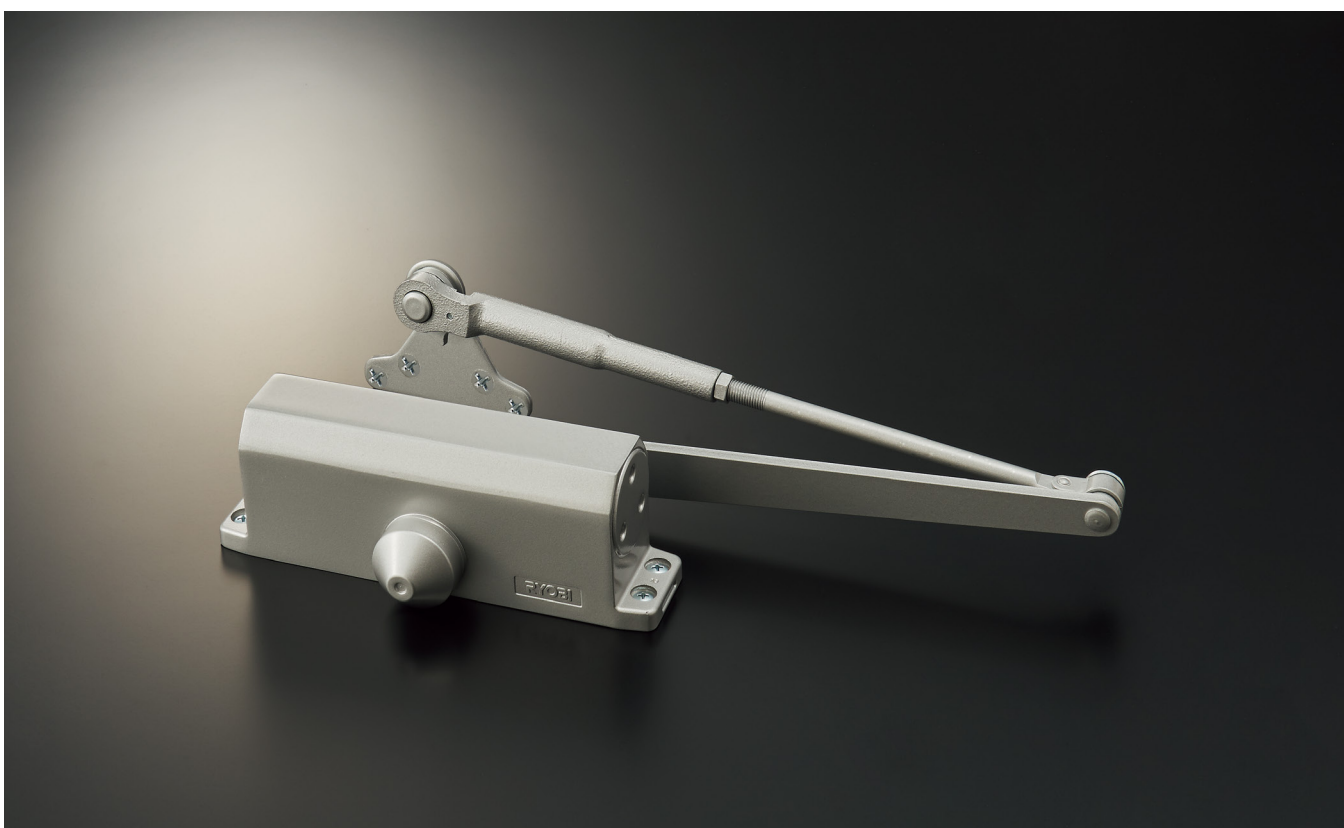

Standard application

Without hold-open 8001
With built-in hold-open 8011

Without hold-open	With built-in hold-open	Maximum door weight	Maximum door width	
			Interior	Exterior
8001	8011	30kg	800mm	

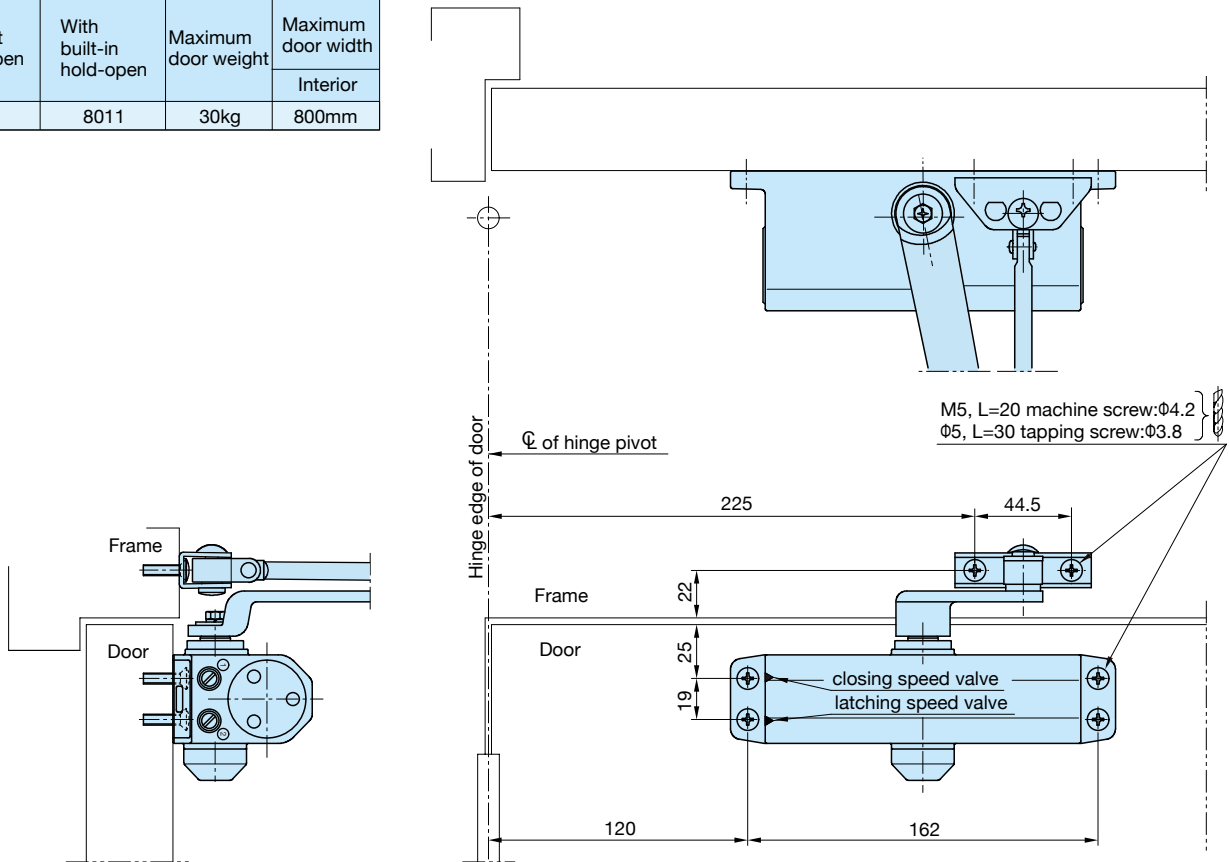

Without hold-open 8002,8003,8004
Without hold-open with backcheck 8002BC,8003BC,8004BC
With built-in hold-open 8012,8013

Without hold-open	With built-in hold-open	A	Maximum door weight	Maximum door width	
				Interior	Exterior
Without backcheck					
8002	8012	188	45kg	900mm	800mm
8003	8013	208	65kg	950mm	900mm
8004		230	85kg	1050mm	950mm
With backcheck					
8002BC		188	45kg	900mm	800mm
8003BC		208	65kg	950mm	900mm
8004BC		230	85kg	1050mm	950mm

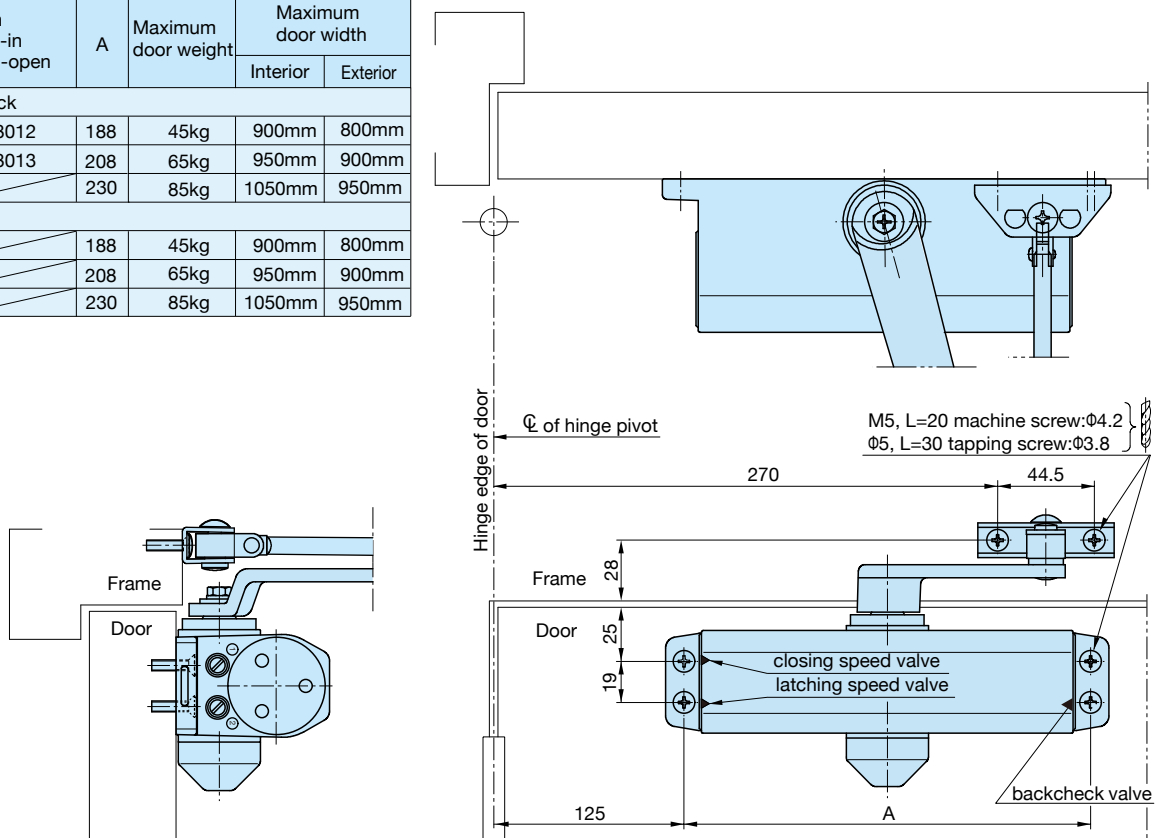

Standard application

Without hold-open 8005,8006

Without hold-open with backcheck 8005BC,8006BC

	Maximum door weight	Maximum door width	
		Interior	Exterior
Without backcheck			
8005	120kg	1200mm	1050mm
8006	150kg	1500mm	1350mm
With backcheck			
8005BC	120kg	1200mm	1050mm
8006BC	150kg	1500mm	1350mm

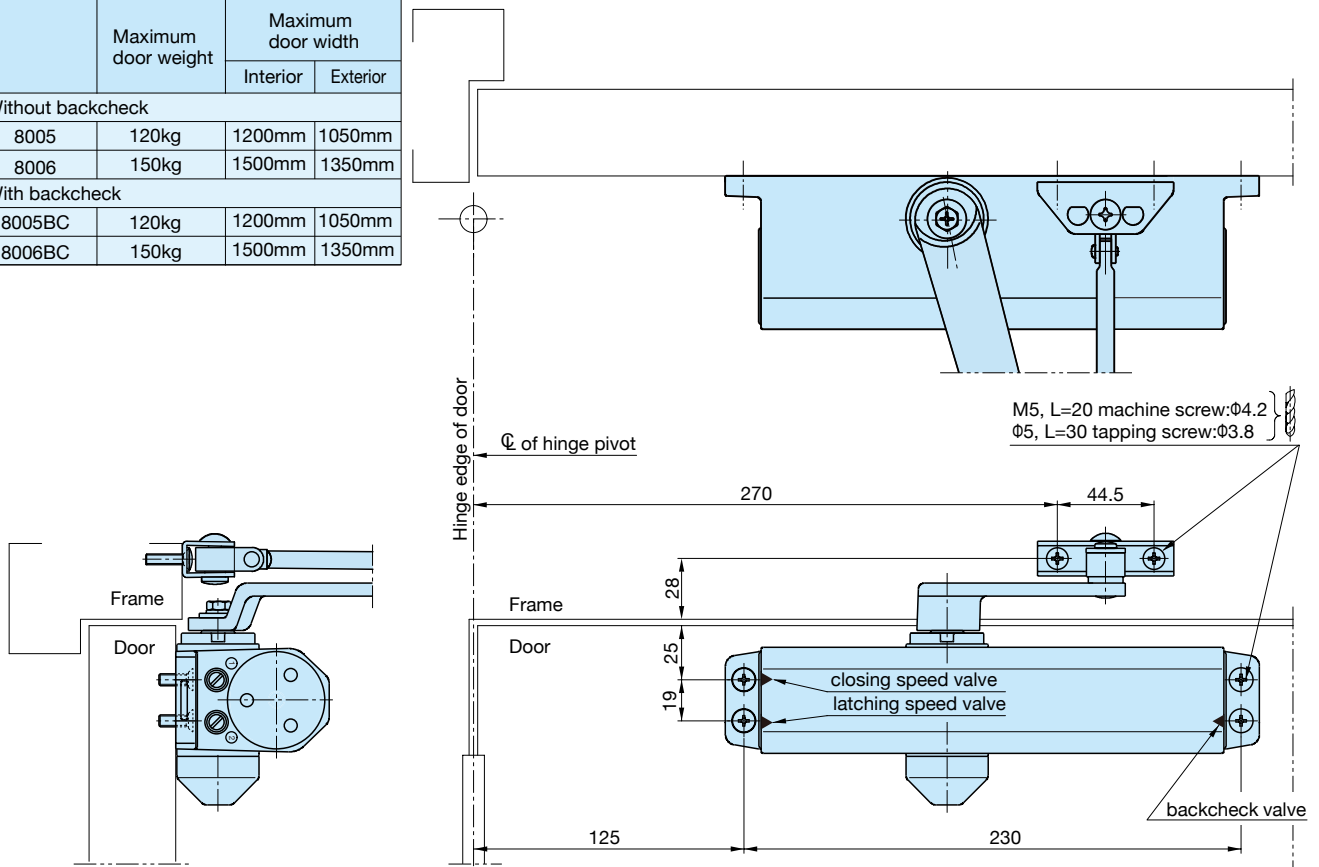

Without hold-open spring adjustable type 8000V,8001V

	Maximum door weight	Maximum door width	
		Interior	Exterior
8000V	45~150kg	900~1300mm	800~1050mm
8001V	30~120kg	800~1200mm	800~950mm

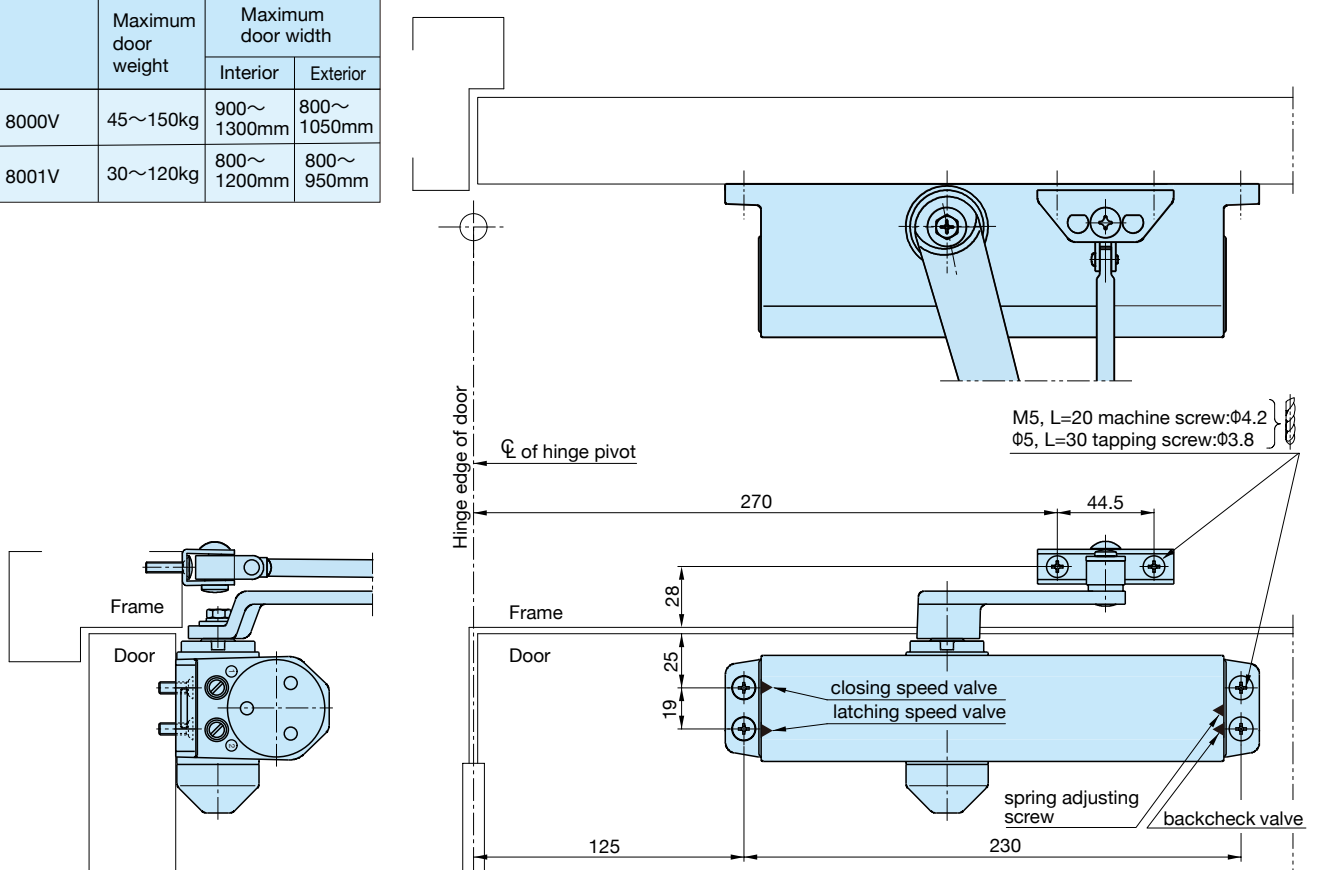

Standard application

With hold-open S-8001

With hold-open	Maximum door weight	Maximum door width	
		Interior	Exterior
S-8001	30kg	800mm	

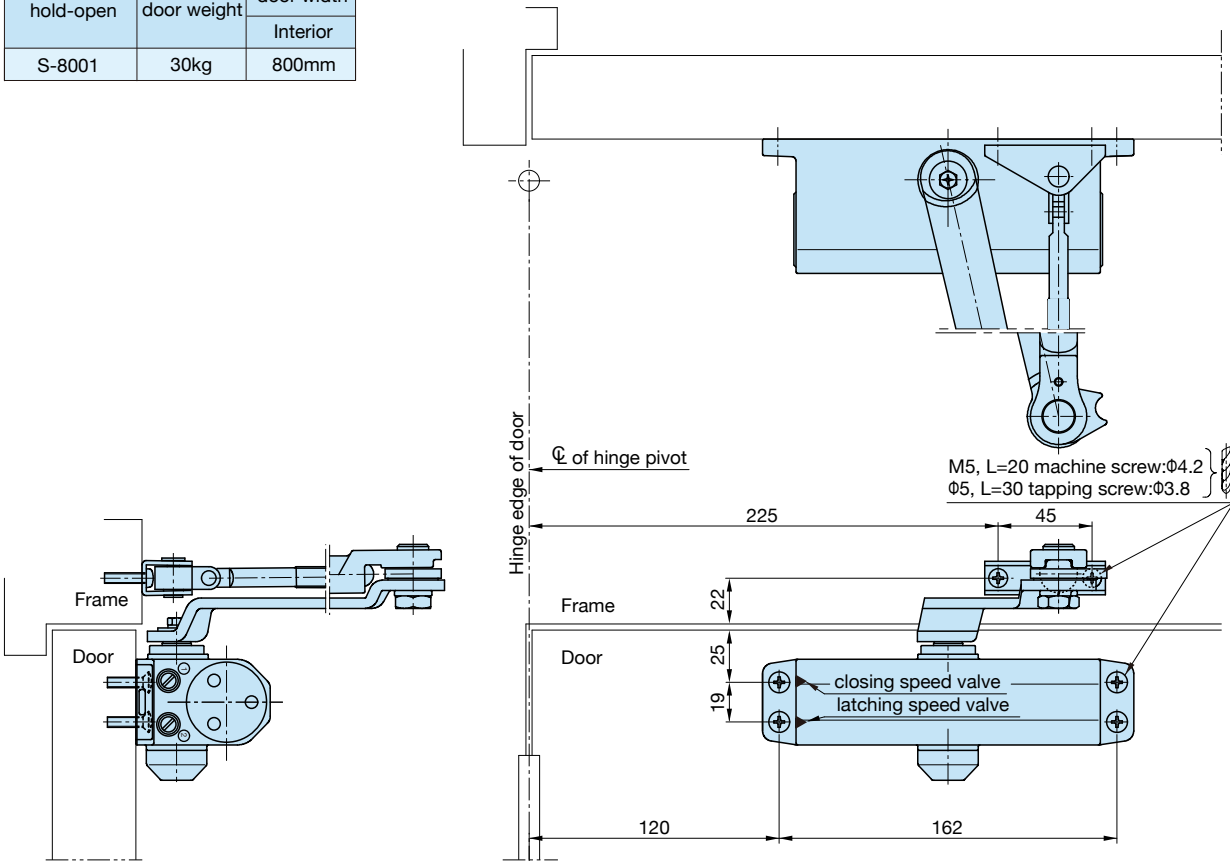

With hold-open S-8002,S-8003,S-8004 With hold-open with backcheck S-8002BC,S-8003BC,S-8004BC

With hold-open	A	Maximum door weight	Maximum door width	
			Interior	Exterior
Without backcheck				
S-8002	188	45kg	900mm	800mm
S-8003	208	65kg	950mm	900mm
S-8004	230	85kg	1050mm	950mm
With backcheck				
S-8002BC	188	45kg	900mm	800mm
S-8003BC	208	65kg	950mm	900mm
S-8004BC	230	85kg	1050mm	950mm

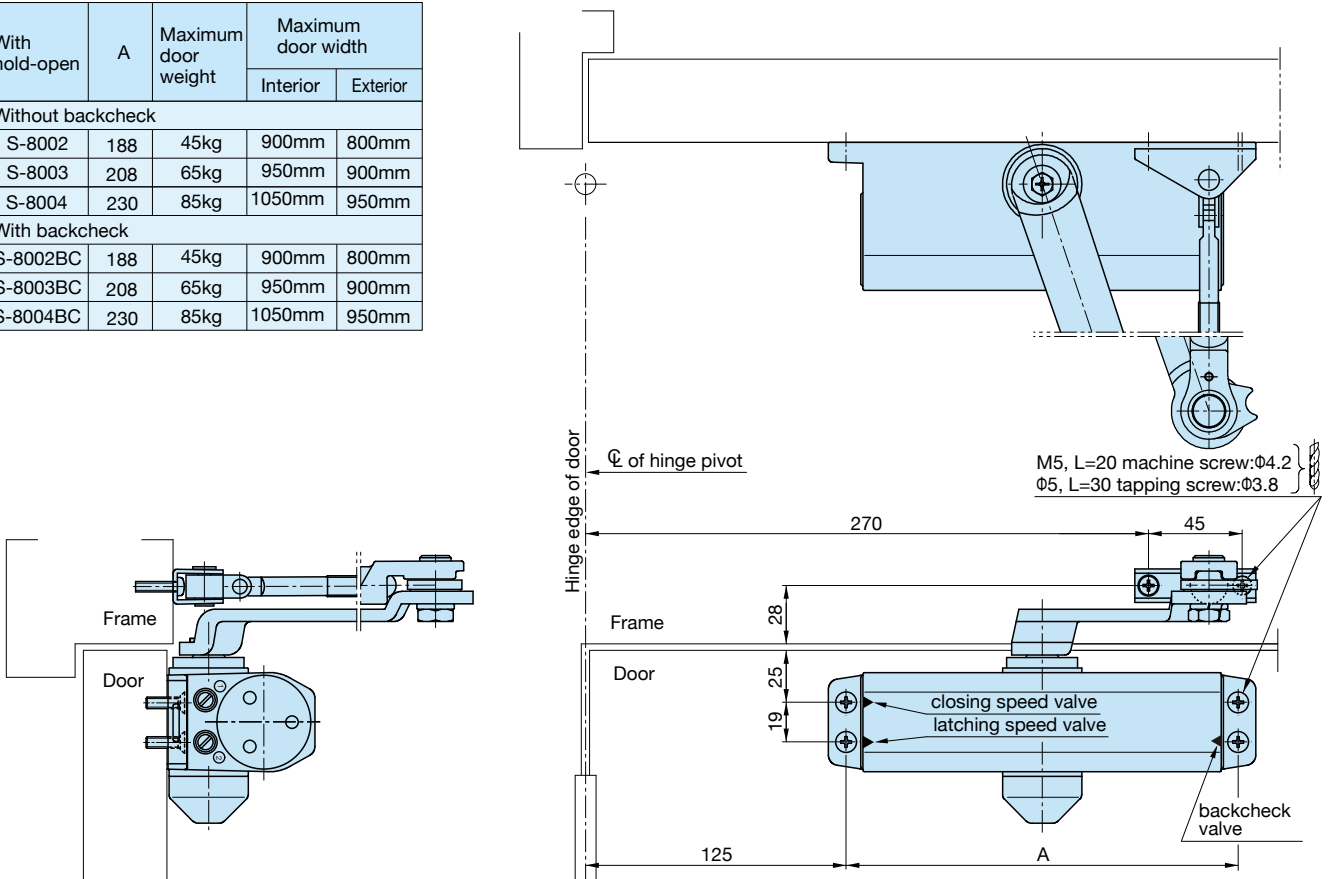

Standard application

With hold-open S-8005,S-8006

With hold-open with backcheck S-8005BC,S-8006BC

	Maximum door weight	Maximum door width	
		Interior	Exterior
Without backcheck			
S-8005	120kg	1200mm	1050mm
S-8006	150kg	1500mm	1350mm
With backcheck			
S-8005BC	120kg	1200mm	1050mm
S-8006BC	150kg	1500mm	1350mm

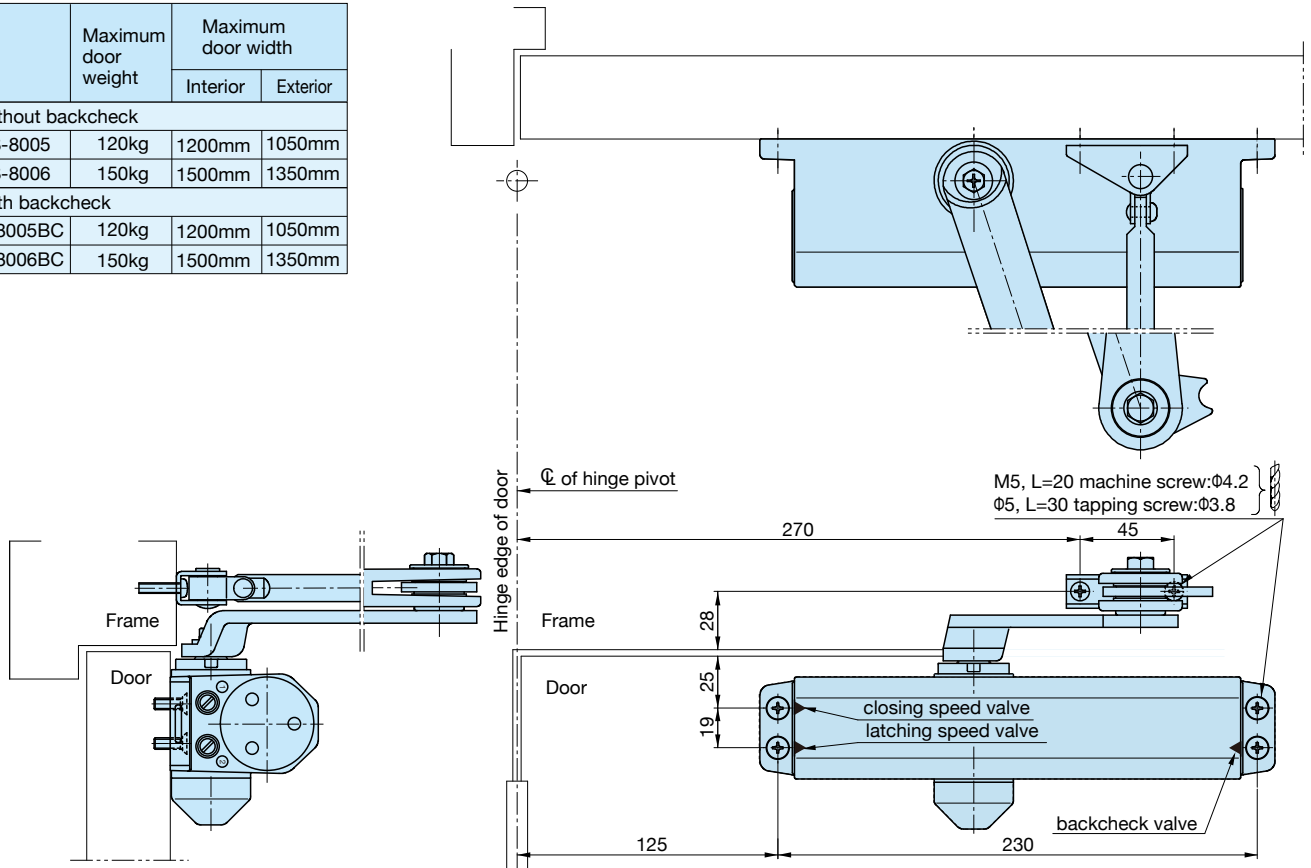

With hold-open spring adjustable type S-8000V,S-8001V

	Maximum door weight	Maximum door width	
		Interior	Exterior
S-8000V	45~150kg	900~1300mm	800~1050mm
S-8001V	30~120kg	800~1200mm	800~950mm

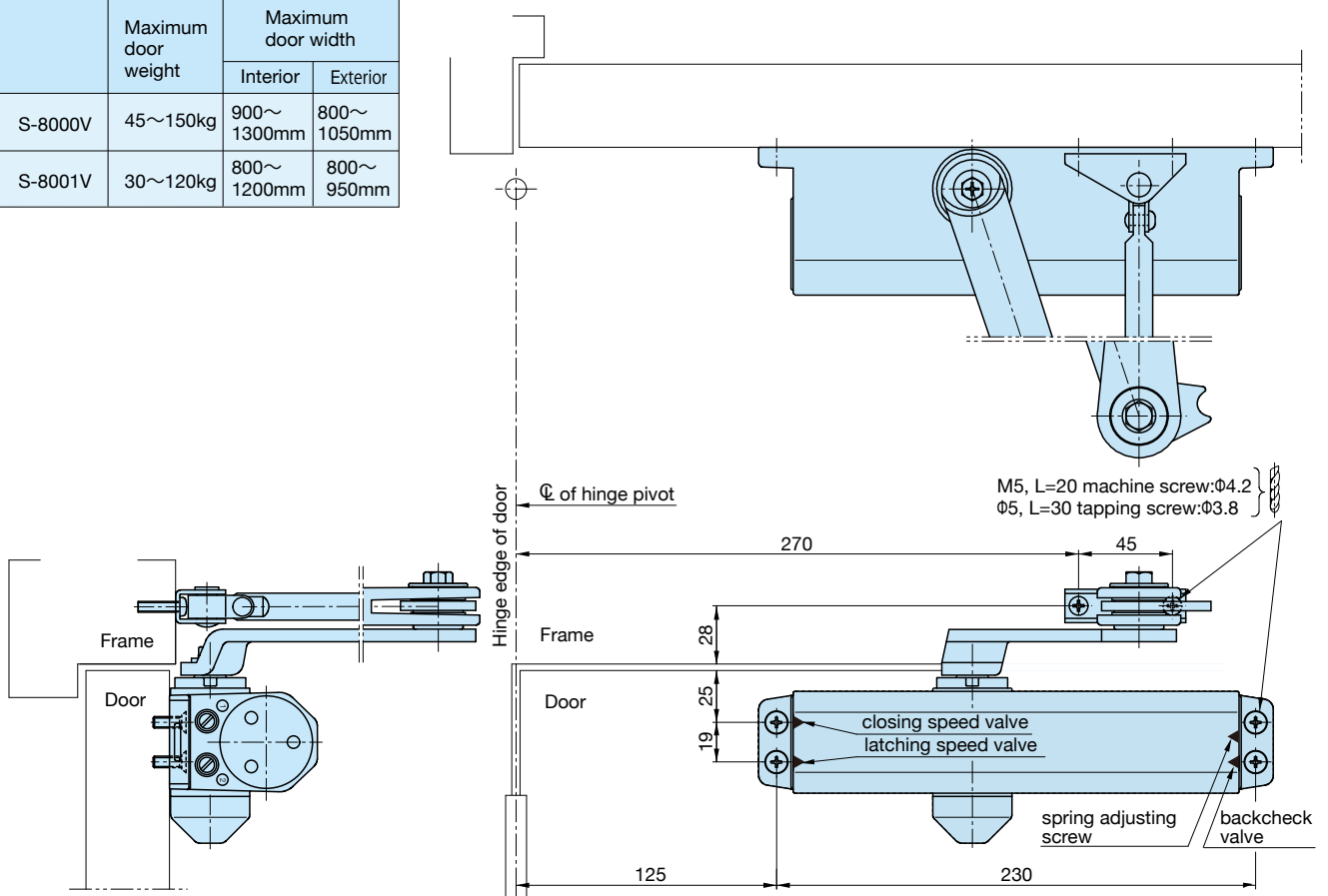

Parallel arm application

Without hold-open 8001P
With built-in hold-open 8011P

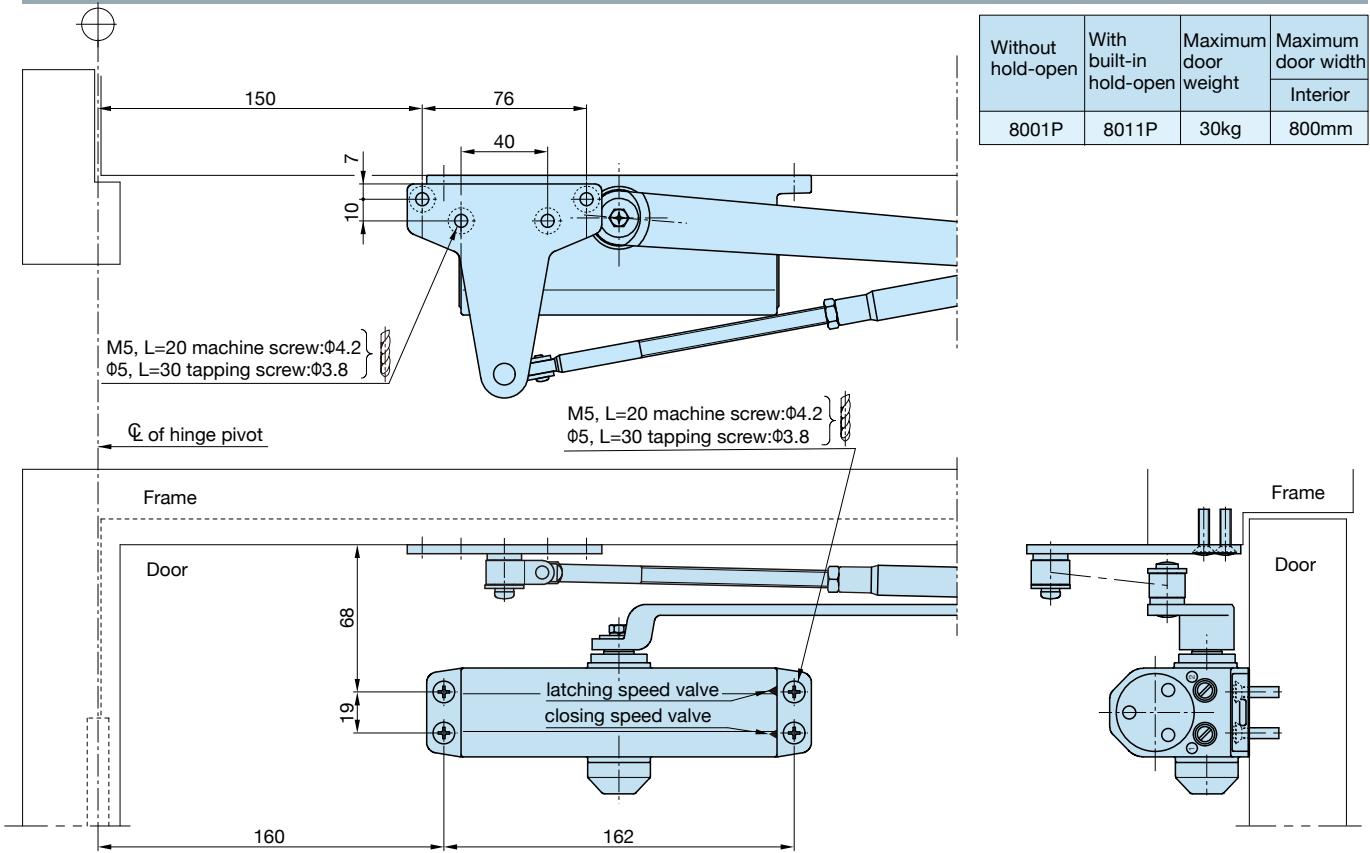

Without hold-open	With built-in hold-open	Maximum door weight	Maximum door width	
			Interior	Exterior
8001P	8011P	30kg	800mm	

Without hold-open 8002P,8003P,8004P
Without hold-open with backcheck 8002PBC,8003PBC,8004PBC
With built-in hold-open 8012P,8013P

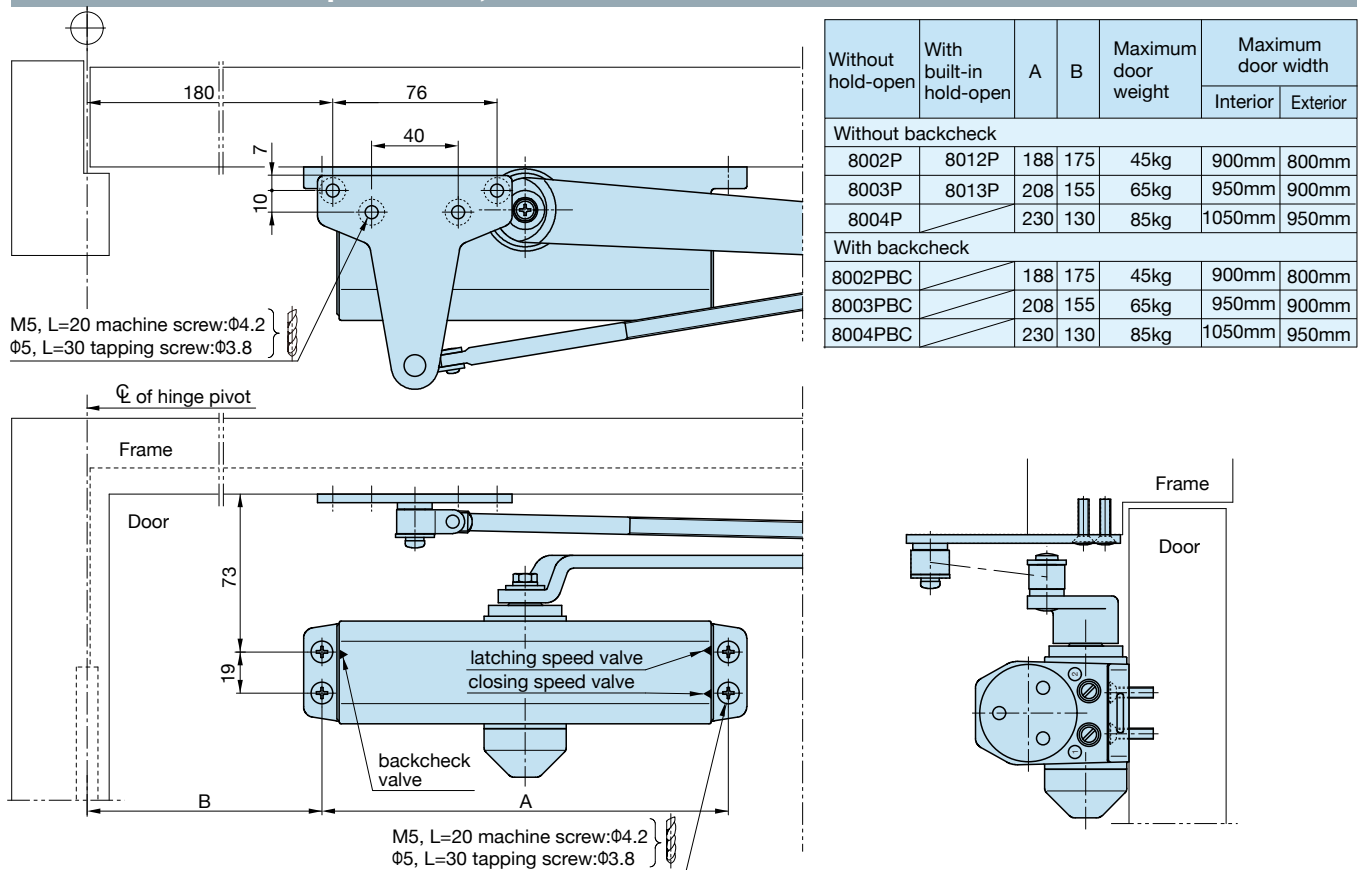

Without hold-open	With built-in hold-open	A	B	Maximum door weight	Maximum door width	
					Interior	Exterior
Without backcheck						
8002P	8012P	188	175	45kg	900mm	800mm
8003P	8013P	208	155	65kg	950mm	900mm
8004P		230	130	85kg	1050mm	950mm
With backcheck						
8002PBC		188	175	45kg	900mm	800mm
8003PBC		208	155	65kg	950mm	900mm
8004PBC		230	130	85kg	1050mm	950mm

Parallel arm application

Without hold-open 8005P,8006P
 Without hold-open with backcheck 8005PBC,8006PBC

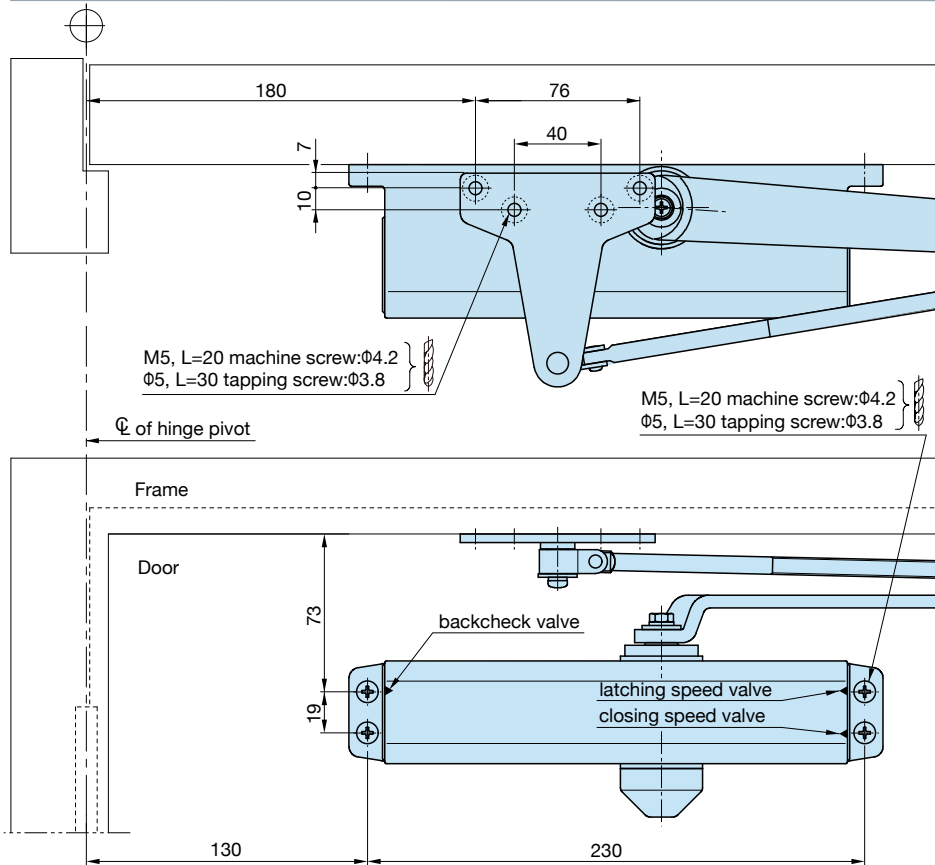

	Maximum door weight	Maximum door width	
		Interior	Exterior
Without backcheck			
8005P	120kg	1200mm	1050mm
8006P	150kg	1500mm	1350mm
With backcheck			
8005PBC	120kg	1200mm	1050mm
8006PBC	150kg	1500mm	1350mm

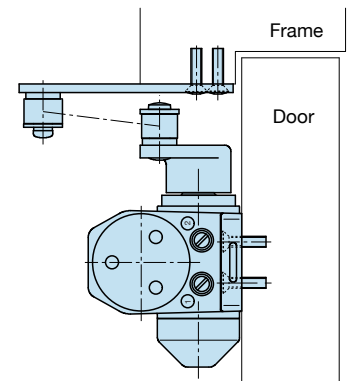

Without hold-open spring adjustable type 8000PV,8001PV

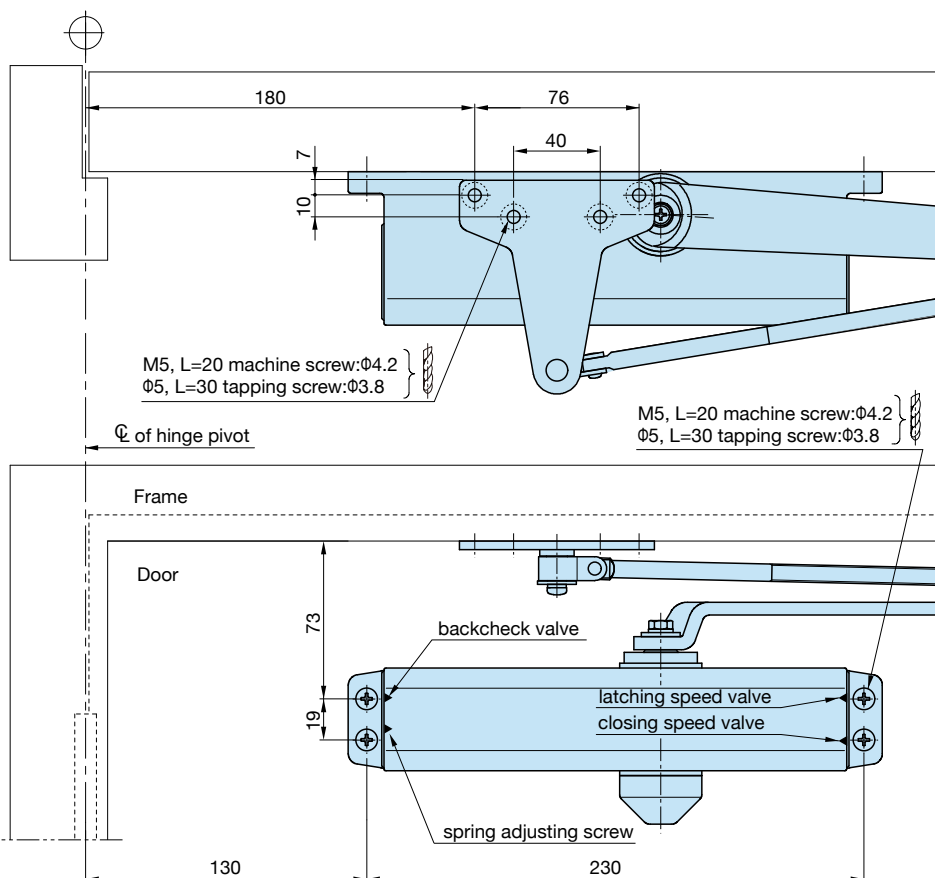

	Maximum door weight	Maximum door width	
		Interior	Exterior
8000PV	45~150kg	900~1300mm	800~1050mm
8001PV	30~120kg	800~1200mm	800~950mm

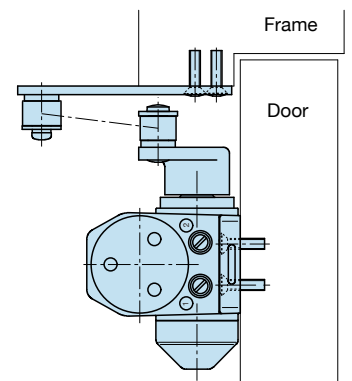

Parallel arm application

With hold-open S-8001P

With hold-open	Maximum door weight	Maximum door width
		Interior
S-8001P	30kg	800mm

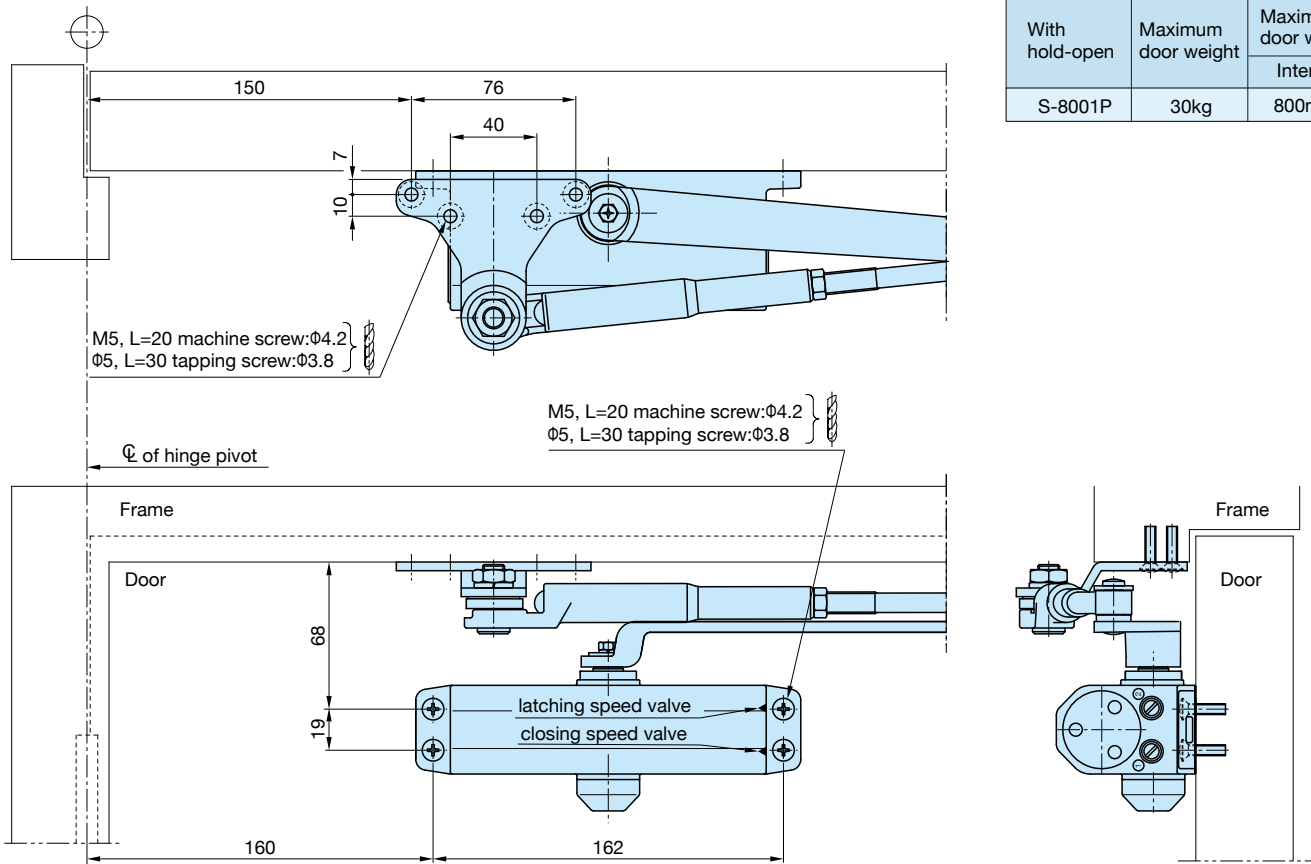

With hold-open S-8002P,S-8003P,S-8004P

With hold-open with backcheck S-8002PBC,S-8003PBC,S-8004PBC

With hold-open	A	B	Maximum door weight	Maximum door width	
				Interior	Exterior
Without backcheck					
S-8002P	188	175	45kg	900mm	800mm
S-8003P	208	155	65kg	950mm	900mm
S-8004P	230	130	85kg	1050mm	950mm
With backcheck					
S-8002PBC	188	175	45kg	900mm	800mm
S-8003PBC	208	155	65kg	950mm	900mm
S-8004PBC	230	130	85kg	1050mm	950mm

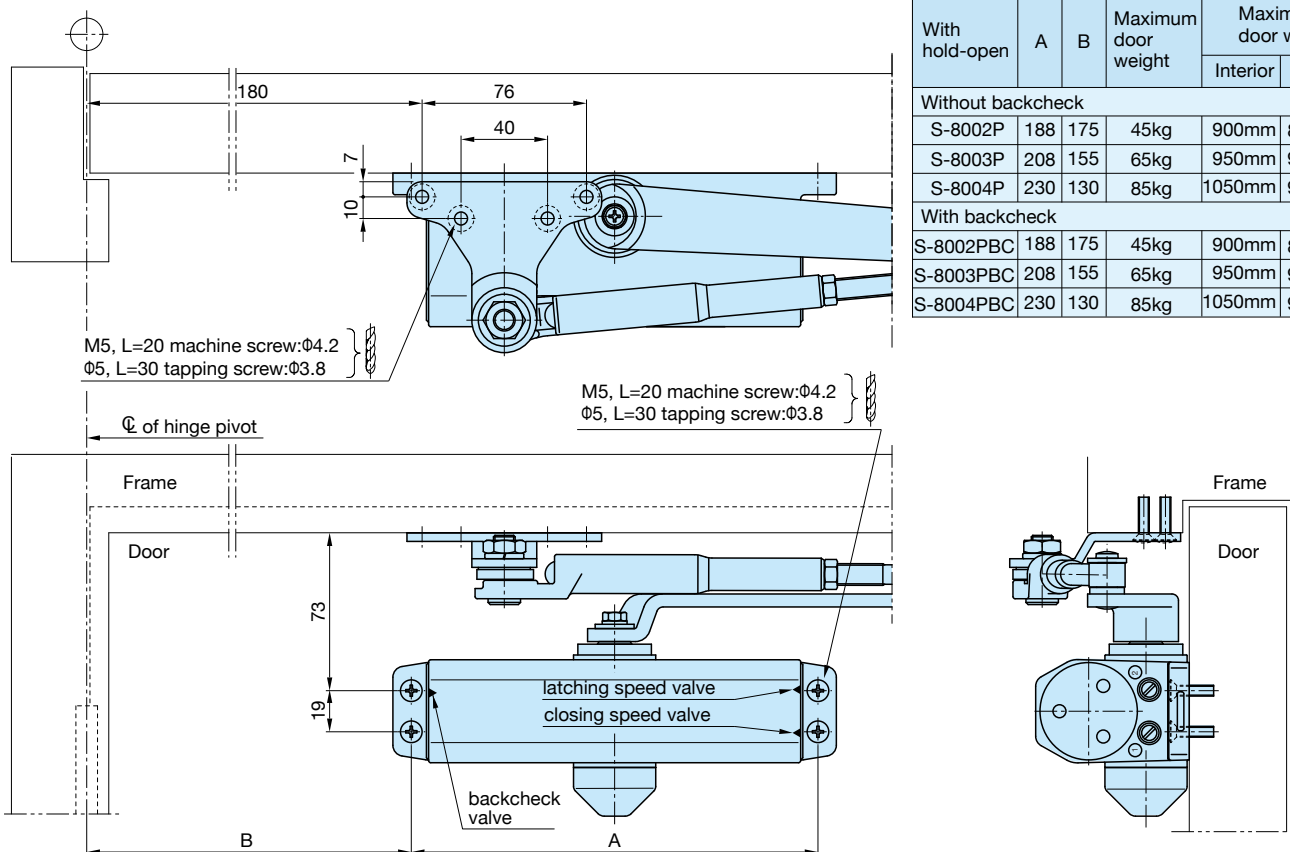

Parallel arm application

With hold-open S-8005P,S-8006P
 With hold-open with backcheck S-8005PBC,S-8006PBC

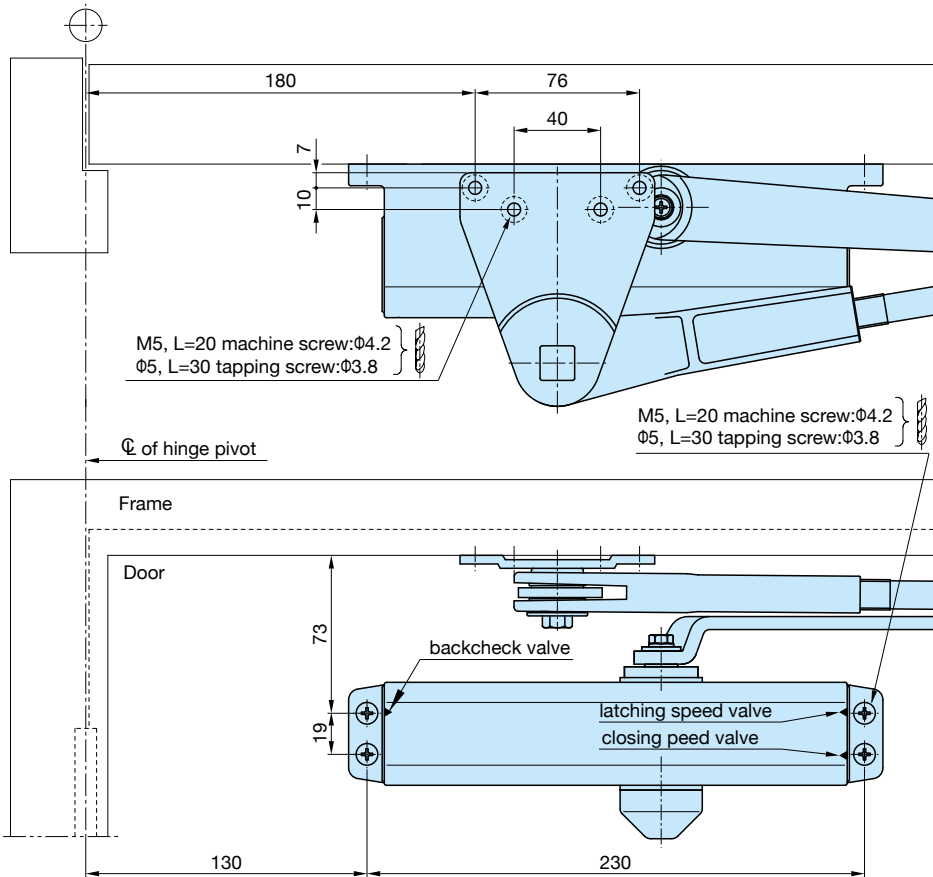

	Maximum door weight	Maximum door width	
		Interior	Exterior
Without backcheck			
S-8005P	120kg	1200mm	1050mm
S-8006P	150kg	1500mm	1350mm
With backcheck			
S-8005PBC	120kg	1200mm	1050mm
S-8006PBC	150kg	1500mm	1350mm

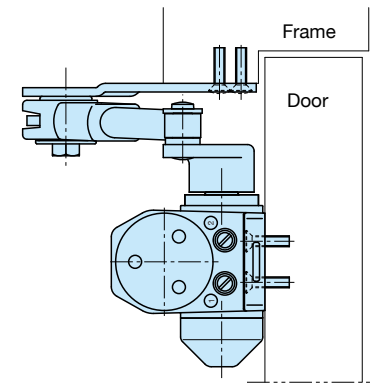

With hold-open spring adjustable type S-8000PV,S-8001PV

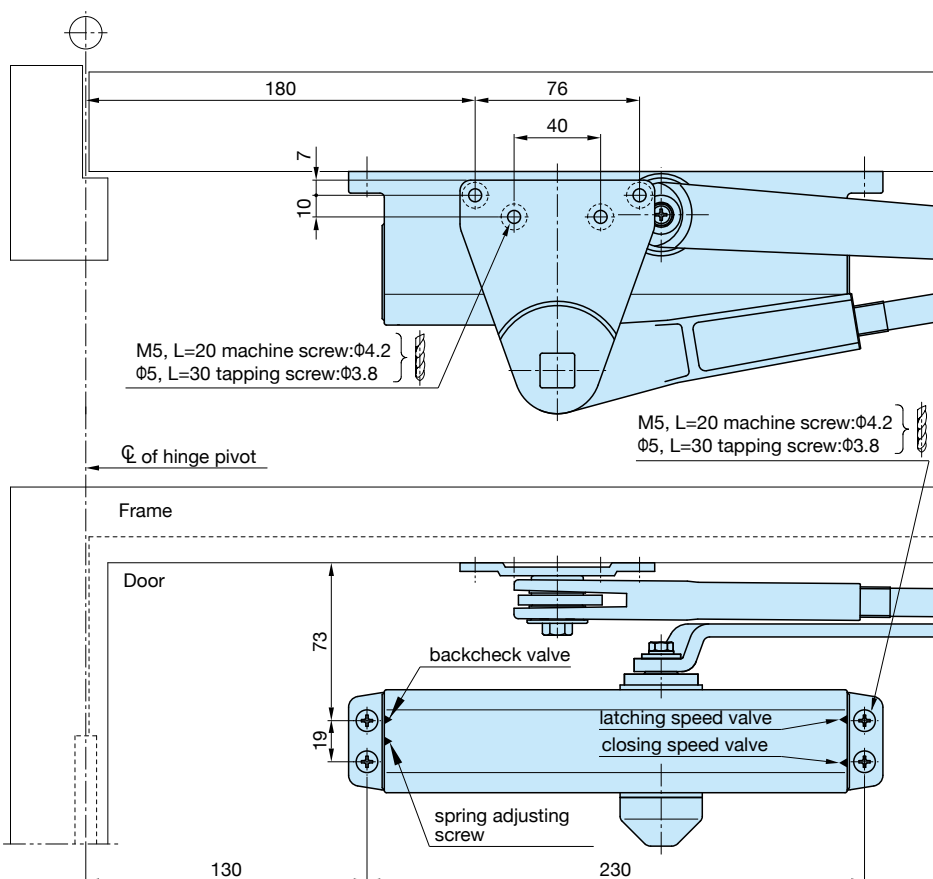

	Maximum door weight	Maximum door width	
		Interior	Exterior
S-8000PV	45~150kg	900~1300mm	800~1050mm
S-8001PV	30~120kg	800~1200mm	800~950mm

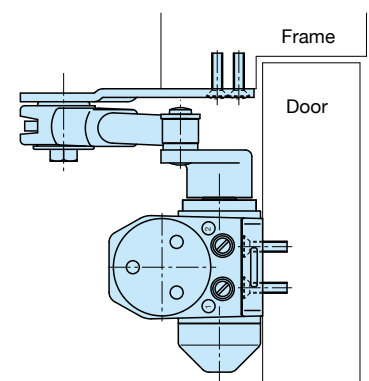

RYOBI LIMITED

5-2-8 Toshima, Kita-ku Tokyo 114-8518, Japan
Tel. 81-3-3927-5536 Fax. 81-3-3927-5527

RYOBI is a registered trade mark of Ryobi Limited